

# JW54 JAW CRUSHER



## STANDARD FEATURES

- ▶ Hydraulic wedge jaw adjustment
  - Internally mounted hydraulics
- ▶ Hydraulic tension rod
- ▶ Electric/hydraulic adjust unit
- ▶ Quick change jaw die wedge system
  - Side access to stationary die
- ▶ High strength frame
  - Four-piece bolted and dowelled construction
  - Cast steel front and rear sections
  - High strength structural steel side sections
  - Machined jaw die support faces
- ▶ Three-piece side cheek plates
- ▶ Reversible corrugated jaw dies
  - Wrap around full height stationary jaw die
  - Lift slots cast into stationary jaw die
  - Extended jaw die frame protection
- ▶ Robust swing jaw design
  - Cast steel swing jaw body
  - Large spherical self-aligning roller bearings
  - Large drop forged steel shaft
- ▶ Replaceable jaw backing plates
- ▶ Right hand drive
- ▶ Mid-mount bolt-on support feet

## OPTIONAL EQUIPMENT

- ▶ V-belt drive
- ▶ Electric motor

# SPECIFICATIONS

# Terex® Minerals Processing Systems JW54 Jaw Crusher

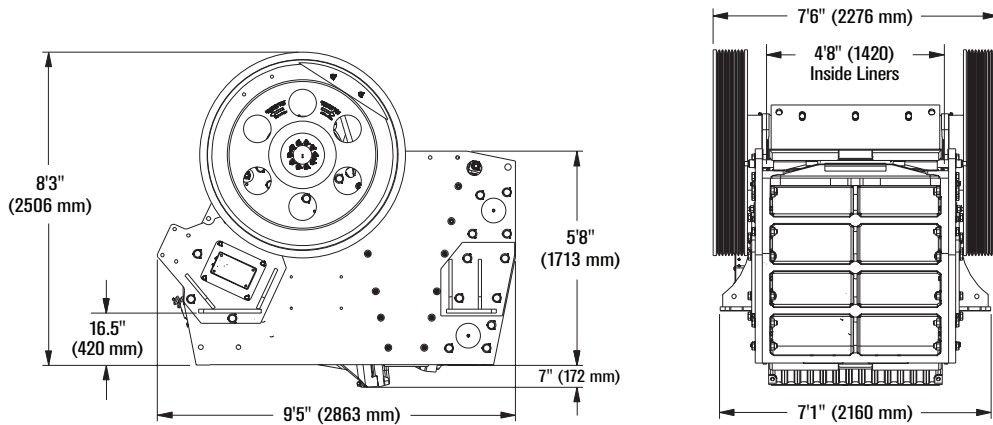

## SPECIFICATIONS

Model	Weight	Horsepower	RPM	Jaw Opening	*Closed Side Setting
JW54	52,000 lbs (23,550 kg)	200 HP (150 kW)	250	32" x 55" (815 x 1400 mm)	4.13" - 8.9" (105 - 225 mm)

\*Closed side setting measured from tip of fixed to bottom of moving jaws.

**JW54 Throughput - Typical Range**  
 (Limestone Application with Pre-Screen removing -75mm)

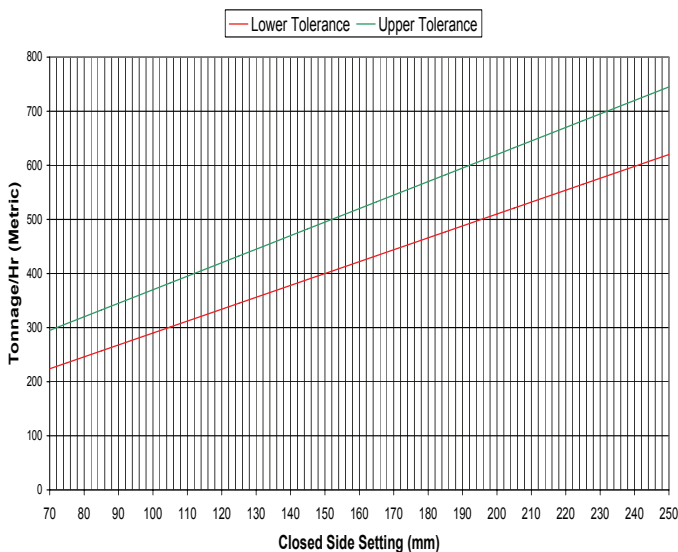

**JW54 Product Gradation**

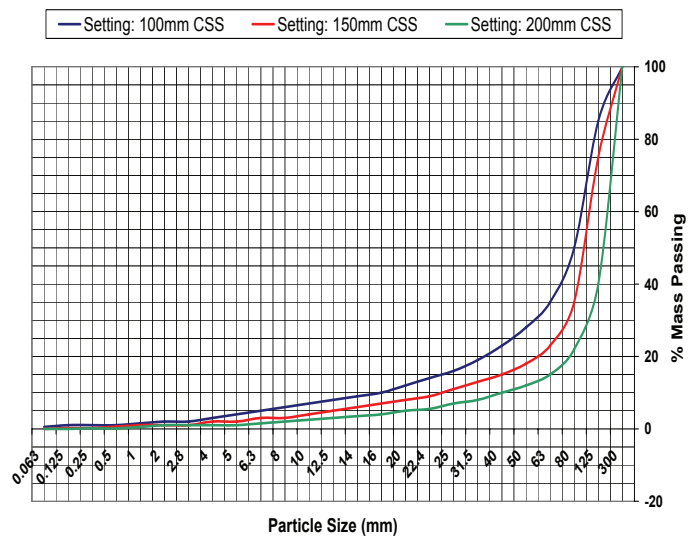

Note: Tonnage and gradations shown are representative only. Actual tonnage and gradations will vary according to application conditions.

[www.terexmps.com](http://www.terexmps.com)

Effective Date: October 2012. Product specifications and prices are subject to change without notice or obligation. The photographs and/or drawings in this document are for illustrative purposes only. Refer to the appropriate Operator's Manual for instructions on the proper use of this equipment. Failure to follow the appropriate Operator's Manual when using our equipment or to otherwise act irresponsibly may result in serious injury or death. The only warranty applicable to our equipment is the standard written warranty applicable to the particular product and sale and Terex makes no other warranty, express or implied. Products and services listed may be trademarks, service marks or trade-names of Terex Corporation and/or its subsidiaries in the USA and other countries. All rights are reserved. Terex is a registered trademark of Terex Corporation in the USA and many other countries. © 2012 Terex Corporation.

Terex® Minerals Processing Systems ▪ [www.terexmps.com](http://www.terexmps.com)  
 India +91 11 4361 0000 or +91 4344 302000 ▪ Malaysia +60 3 5631 6199 ▪ Thailand +66 38 214761  
 Europe, Middle East, Africa +44 (0) 28 82 418 790 ▪ Australia +61 3 8551 9300 ▪ North & South America +1 989 288 3121

Form 25898 A4 (10/12)



**WORKS FOR YOU.™**